

### DESCRIPTION

The F-122C ceiling and wall-mounted speaker covers an extremely wide area and can be used for 25, 70 and 100 V line applications. Well-balanced sound can be heard uniformly at any location.

### SPECIFICATIONS

|                         |  |
|-------------------------|--|
| Enclosure               | Bass reflex type   |
| Rated Input             | 30 W (High Impedance)  |
| Power Handling Capacity | Continuous pink noise: 60 W (8 Ω), 30 W (16 Ω)<br>Continuous program: 120 W (8 Ω), 60 W (16 Ω)   |
| Impedance               | 100 V line: 330 Ω (30 W), 1 kΩ (10 W), 3.3 kΩ (3 W), 10 kΩ (1 W)<br>70 V line: 170 Ω (30 W), 330 Ω (15 W), 1 kΩ (5 W), 3.3 kΩ (1.5 W), 10 kΩ (0.5 W)<br>25 V line: 170 Ω (3.7 W), 330 Ω (1.9 W), 1 kΩ (0.6 W), 3.3 kΩ (0.2 W), 10 kΩ (0.06 W)<br>16 Ω, 8 Ω |
| Sound Pressure Level    | 90 dB (1 W, 1 m)   |
| Frequency Response      | 70 Hz – 20 kHz (–10 dB), 50 Hz – 20 kHz (–20 dB)<br>at installation in 1/2 free sound field<br>(Measured by installing the unit in the center of a ceiling.)   |
| Speaker Component       | 12 cm cone-type  |
| Mounting Hole           | ∅200 mm (Maximum ceiling thickness: 37 mm)   |
| Input Terminal          | Removable locking connector with screw-down terminals<br>(2 input terminals and 2 bridge terminals)  |
| Usable Cable            | Solid copper wire: ∅0.5 – ∅1.6 mm (equivalent to AWG No. 24 – 14)<br>Stranded copper wire: 0.2 – 2.5 mm <sup>2</sup> (equivalent to AWG No. 24 – 14)   |
| Finish                  | Enclosure: Steel plate, plating<br>Baffle: Fire-resistant ABS resin (resin material grade: UL-94 V-0), black<br>Rim: Fire-resistant ABS resin (resin material grade: UL-94 V-0), white, paint<br>Punched net: Steel plate, white, paint                    |
| Dimensions              | ∅230 × 229 (D) mm  |
| Weight                  | 3.7 kg (including mounting accessories)  |
| Accessory               | Panel ∙1, Ceiling reinforcement ring ∙1, Safety wire ∙1, Paper pattern ∙1  |
| Option                  | Digital processor: DP-0206, Anchor hanging bracket: HY-AH1,<br>Back can: HY-BC1, Tile bar bridge: HY-TB1, Trim ring: HY-TR1  |

### APPEARANCE

[Note] The F-122C is used with the DP-0206 Digital processor.

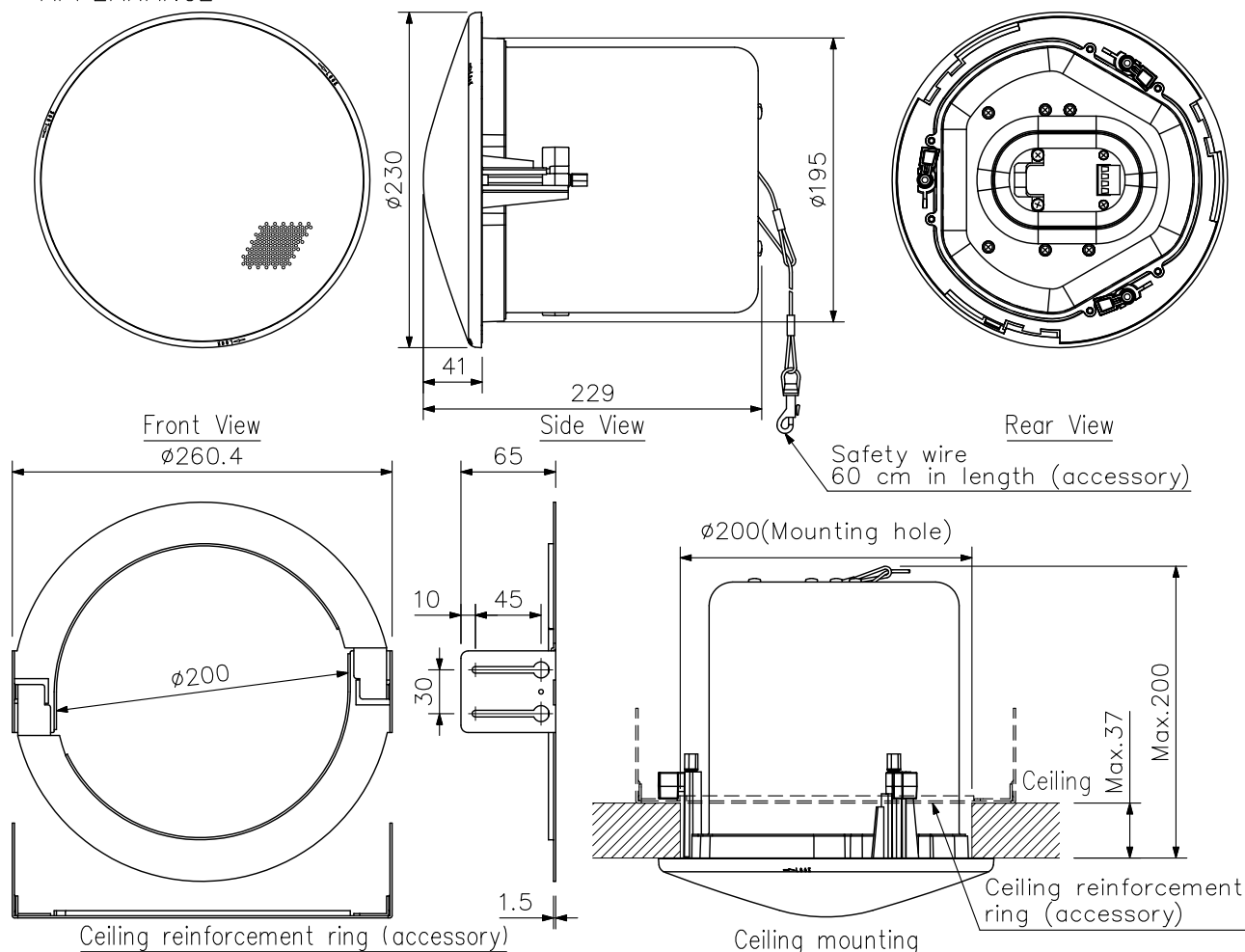

UNIT: mm SCALE: 1/5